



The **CEILING TILE HOLDERS** are useful accessories suitable both for projector lifts SI and SI-H L series. This accessory helps installers to reach a perfect aesthetic result when the projector lift is hidden inside the false ceiling.

The packaging includes the aluminium frame and the brackets for fixing the threaded rods, which are included with the projector lift.

- Width of the aluminium frame seen from the bottom side: 30 mm.
- Packaging includes: aluminium frame divided in 4 pieces, 2 brackets for fixing the threaded rods, bolts and nuts
- Packaging does NOT include: tile for the false ceiling and threaded rods
- **Aluminium frame is supplied RAW**, without any painting. The installer can spray it with a colour at his choice.

CEILING TILE HOLDER CT-570

It is compatible with the following lifts models:

- SI-30
- SI-100
- SI-200

- SI-H L 100
- SI-H L 200
- SI-H L 300

Front view

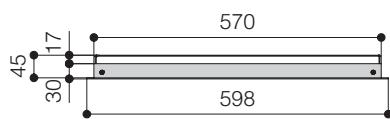

Top view

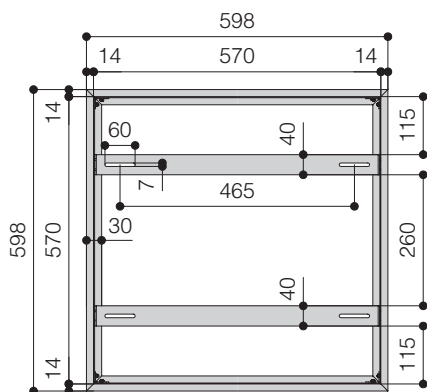

CEILING TILE HOLDER CT-660

It is compatible with the following lift model:

- SI-H L 40 HC

Front view

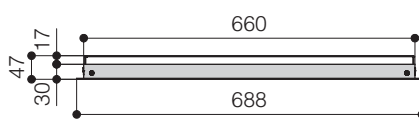

Top view

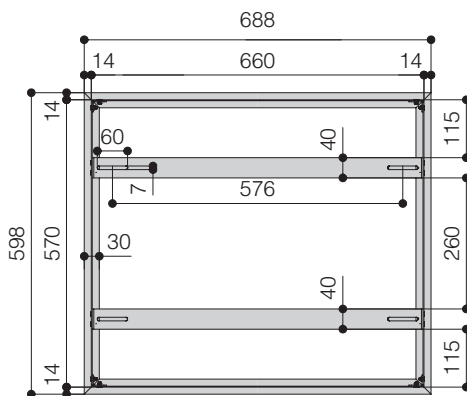

CEILING TILE HOLDER CT-720

It is compatible with the following lift model:

- SI-H L 50 HC

Front view

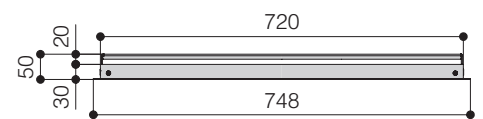

Top view

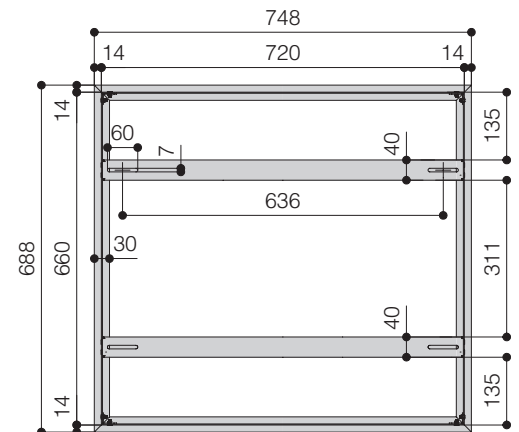

The measures in the drawings are expressed in millimetres.

Warranty: 24 months

www.screenint.com

